

Drawing ID

C-WFM

Product Info.

Finish	Code
Polish	C-WFM
Satin	C-WFS
Texture Black	C-WFB
White	C-WFW
Brush Brass	C-WFBB

Dimensions

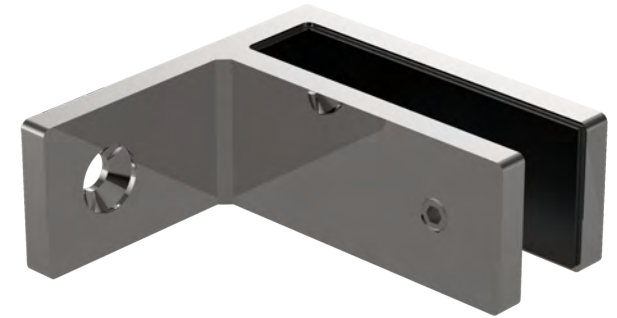
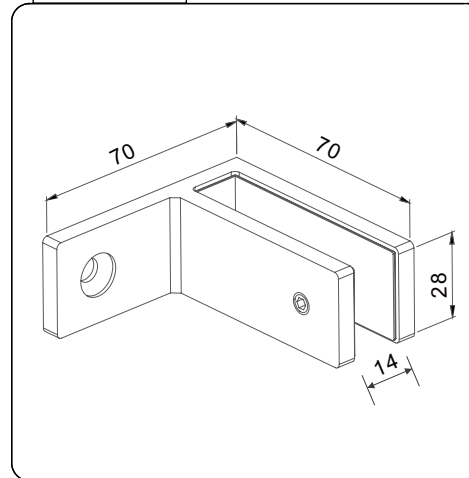

Dimensions

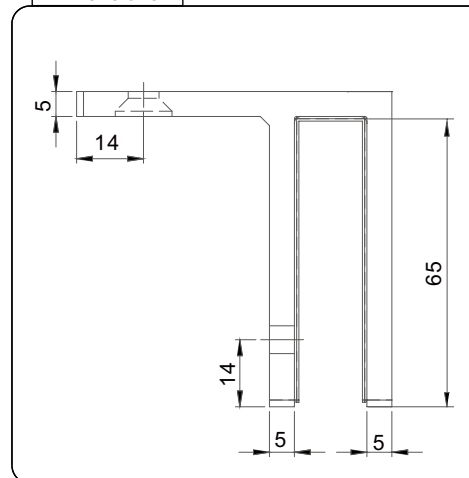

Top View

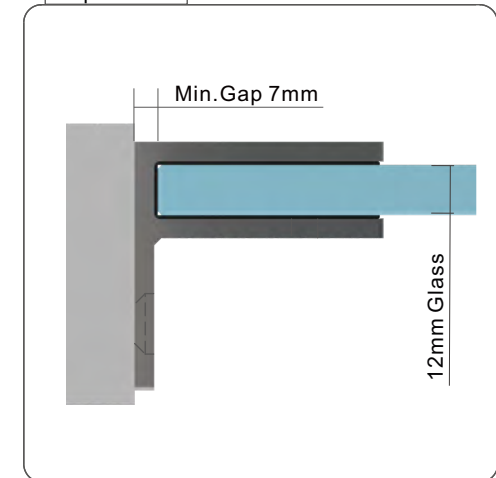

MATERIAL:

Duplex 2250 Stainless Steel

CATALOGUE AND DESCRIPTION:

- > Glass Fixing System
- > Glass Clamp
- > Friction Fit Glass to Wall Clamp

NOTES:

This drawing and or specification is the property of Silver Stone Hardware Pty Ltd - and must be returned to them on request. Unauthorised use may result in Legal Action. Its contents must not be made public, nor copied, nor used directly or indirectly in any way.

SILVER STONE HARDWARE PTYLID

56-62 Bryant Street, Padstow, NSW 2211
 T: (02) 9792 2955 M: 0452 526 680
www.silverstonehardware.com.au
sales@silverstonehardware.com.au